

Engineering Data and Specifications

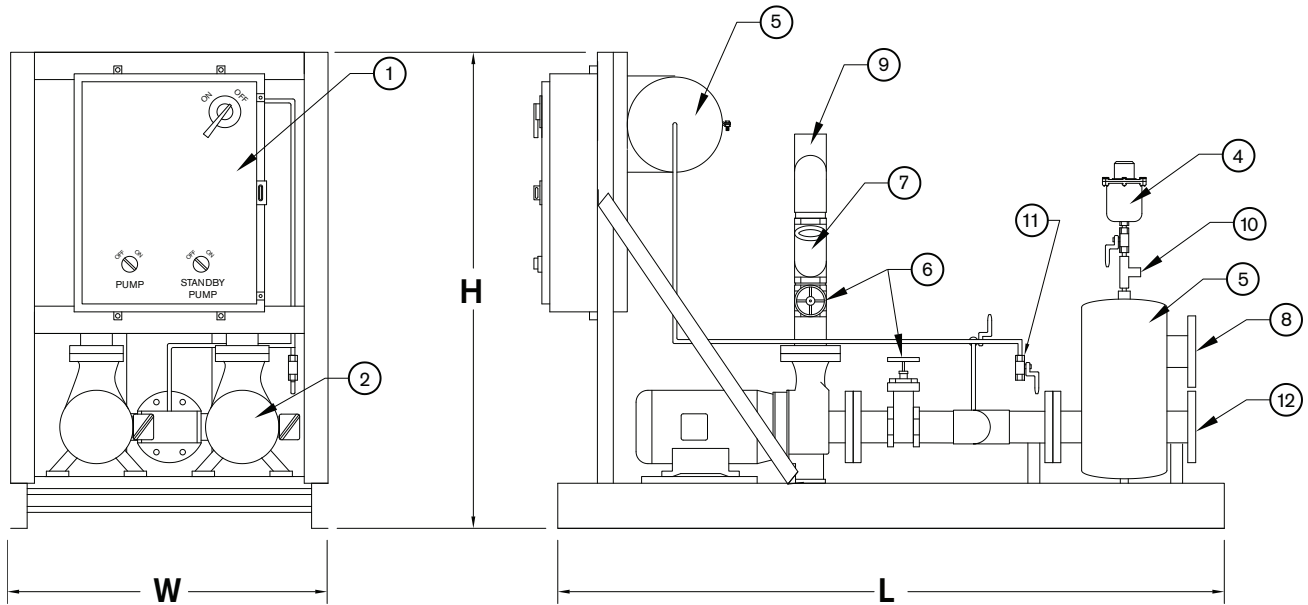

Legend

- | | | |
|---------------------|----------------------|------------------------|
| 1 – Control Panel | 5 – Expansion Tank | 9 – System Outlet |
| 2 – Pump(s) | 6 – Isolation Valves | 10 – Cold Water Refill |
| 3 – Air Separator | 7 – Check Valve(s) | 11 – Drain |
| 4 – Air Eliminators | 8 – System Inlet | 12 – Strainer Access |

Pump Station	Frame Dimensions in			Pump Horsepower each	Maximum Flow Rate GPM	Connection Size in	Shipping Weight [†] lb
	L	W	H				
PS-075*	58	30	60	1.5	75	2	595
PS-125*	58	30	60	3	125	2.5	620
PS-200*	74	40	60	5	200	3	810
PS-300**	74	40	60	10	300	3	895
PS-400**	74	40	60	15	400	4	945
PS-500**	100	40	60	20	500	4	1320
PS-750**	100	50	60	25	750	5	1440

* PS-075 thru PS-200 nominal design – 50 feet available system head loss

**PS-300 thru PS-750 nominal design – 80 feet available system head loss

Expansion tank based on pressure at the tank, $P_{initial} = 12$ psi and $P_{max} = 30$, $T_{mean} = 100F$ and system volume equal to 2x minimum flow rate

[†]Approximate weight

Specifications

1.0 **General:**

Furnish _____ Recold model PS- _____ pumping station(s). The station frame shall not exceed _____ length, _____ width and _____ height. The station(s) shall be factory assembled and leak tested prior to shipping.

1.1 **Capacity:**

The pumping station(s) shall have the capacity to circulate _____ GPM of _____ at a system head loss of _____ feet.

1.2 **Pump(s):**

A minimum of _____ close coupled, standard fitted centrifugal pump(s) with a mechanical seal shall be mounted and piped on a base frame. A maximum _____ hp pump motor(s) operating on _____ volts, 3 phase and _____ hertz power shall be provided.

1.3 **Air Separation/Eliminator:**

Air separator shall be tangential with integral removable strainer. The separator shall be constructed in accordance with ASME code. An automatic air vent shall be provided for positive air elimination.

1.4 **Expansion Tank:**

A diaphragm expansion tank shall be provided. The tank shall be assembled per ASME code. The steel shell tank shall be equipped with a heavy duty elastomer diaphragm and an air charging valve.

1.5 **Control-Starter Panel:**

A single NEMA 12 enclosure wired to the motor(s) shall be provided. A through-the-door non-fused disconnect, fuse protection for individual pump motor legs and thermal overloads shall be provided with the motor starter(s). A 120-1-60 control circuit transformer shall be included with fused primary and secondary circuits. A terminal strip for remote control or monitoring by a building automation system is available.

1.6 **Unit Construction:**

PS-50 through PS-300 standard piping is schedule 80 PVC – schedule 40 galvanized steel is optional. PS-400 and above have schedule 40 galvanized steel piping. Gate or butterfly valves shall be provided to isolate pump(s) for servicing or replacement. The station frame shall be constructed out of heavy gauge galvanized steel for superior corrosion protection